

VLK 80/R

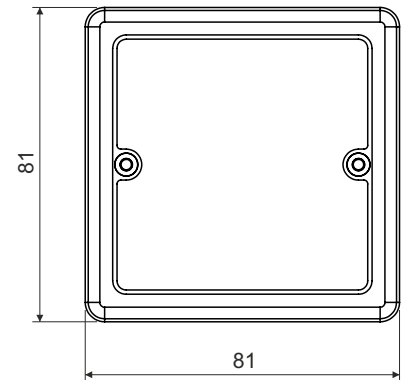
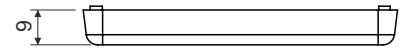

:

LK 80R/1, LK 80R/2, LK 80R/3, LK 80X20R/1, LK 80X28R/1, LK 80X28 2R

:

: RAL 9003

: , 30

: -5 - +60 °C

: 850 °C

: A1-F

: 22

: EN 60 670-1